



LET'S BUILD A BETTER FUTURE

■ Façade system **MB-MM50N**

The ALUPROF MB-MM50N façade is a state-of-the-art, mullion-to-mullion structure created in response to the increasingly high demands placed on contemporary curtain wall systems. Developed primarily for the Scandinavian market, it provides a number of unique architectural, constructional and functional features that set it apart from other systems. The excellent thermal performance makes it possible to turn designs for buildings with an emphasis on high energy efficiency into reality.

The MB-MM50N has visible profiles which are 50 mm wide and is structurally related to the ALUPROF MB-MT50N. As a result, the components and manufacturing process correspond to the requirements of sustainable development and the concept of a circular economy. The solutions used in the system facilitate both optimising the quantities of material essential to making the façade and minimising the time required to install the structure on site. The MB-MM50N offers numerous features that simplify prefabrication and storing the parts, which is a major advantage for façade manufacturers.

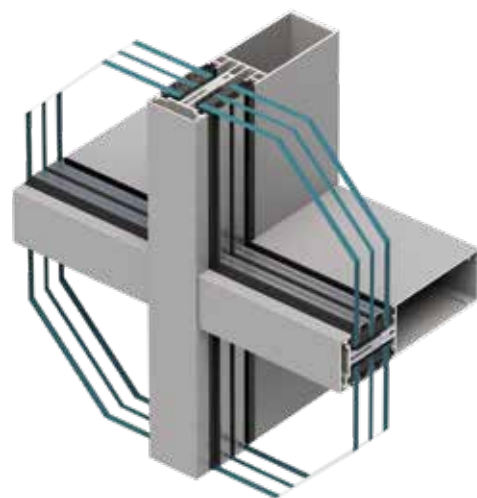

U_f from 0,62 W/(m²K)

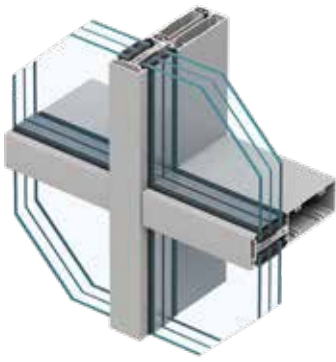

MB-MM50N SI

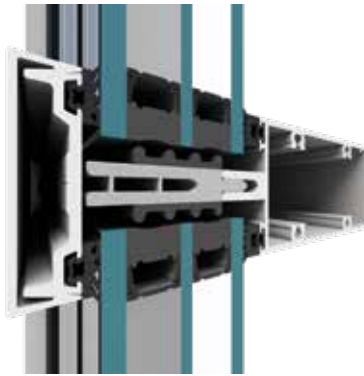

MB-MM50N SI

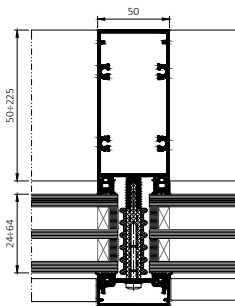

Cross-sectional view through a mullion

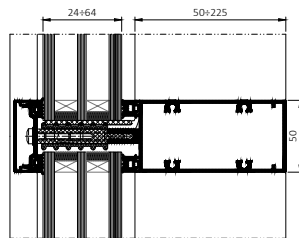

Cross-sectional view through a transom

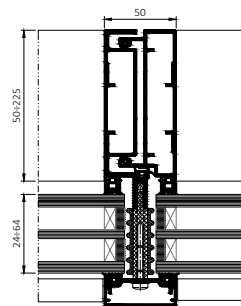

Cross-sectional view through a half-mullion

FEATURES AND AESTHETICS

- a series of profiles with dimensions from 50 to 225 mm
- the frames of a structure can be built from one profile
- insulating glass units with a thickness of 24 to 64 mm can be used
- high load-bearing mullion-transom connectors mean that glass weighing up to 880 kg can be used
- simple, automated processing of profiles and accessories
- the mullions and transoms are cut straight eliminating labour-intensive processing such as cutting a transom to adjust it and streamlining the fabrication process for a structure significantly
- the system shares TORX screws and two-component PET/PE insulators with the MB-MT50N façade
- the gaskets ensuring high-performance air- and watertightness are the same as for the MB-MT50N
- the profiles can be screwed together on the shop floor and the ladders can be assembled there
- the series of half-mullions, measuring from 50 to 225 mm enable the rapid assembly of ladders and segments. They are also suitable for the MB-MT50N profiles
- the profiles are used to reinforce the mullions and also as connector profiles
- infill drainage and ventilation are provided to each infill area by openings in the horizontal clamping strip
- the system is compatible with fixing solutions from ADJUFIX, which are popular on the Scandinavian market

PERFORMANCE	MB-MM50N
Air permeability	AE 1200 Pa
Watertightness	RE 1200 Pa
Windload resistance	2400 Pa
Thermal insulation	U_f from 0,62 W/(m ² K)